



# CHIPPING HAMMERS (NC-series)

## APPLICATIONS

Road construction and repairing. Cutting, scraping and spot calking at buildings, casting foundries, mines, quarries, etc.

### ● AK-NC0S

with SPRING chisel retainer



### ● AK-NC0H

with chisel HOLDER



### ● AK-NC1S

with SPRING chisel retainer



### ● AK-NC1H

with chisel HOLDER



### ● AK-NC2S

with SPRING chisel retainer



### ● AK-NC2H

with chisel HOLDER



### ● AK-NC3S

with SPRING chisel retainer



### ● AK-NC3H

with chisel HOLDER



### ● AK-NC4S

with SPRING chisel retainer



### ● AK-NC4H

with chisel HOLDER



Model	Piston Dia (mm)	Piston Stroke (mm)	Blows (bpm)	Air Cons. (L/min)	Air Inlet (inch PT)	Weight (kg)	Overall Length (mm)	Shank Size (mm)	
								Round	Hex.
AK-NC0S	20	45	3000	350	3/8	2.4	280	12.7x47	11x47
AK-NC1S	28.5	26	3000	550	1/2	5.5	355	17.5x60	15x60
AK-NC2S	28.5	51	2600	600	1/2	6.1	395	17.5x60	15x60
AK-NC3S	28.5	76	2300	600	1/2	6.5	440	17.5x60	15x60
AK-NC4S	28.5	102	1800	650	1/2	6.9	478	17.5x60	15x60



SAITAMA SEIKI CO., LTD.

2942 Mishiri, Kumagaya, Saitama, 360-0843 Japan

Tel. +81-48-532-3804 FAX +81-48-533-3883

201304



## CHIPPING HAMMERS (AA-series) & FLUX CHIPPERS

### APPLICATIONS

**AA-series:** Same as NC-series, but AA-series have shorter stroke and more frequent impacts, and less vibration, which are suitable for finer jobs.

**Flux Chippers:** Stone engraving, removal of paint, rust and welding chips.

Most suitable for cutting and scraping at small area. Operationable by a small compressor.

### ● AK-AA10A

with SPRING chisel retainer



### ● AK-AA15A

with SPRING chisel retainer



### ● AK-AA20S

with SPRING chisel retainer



### ● AK-AA30S

with SPRING chisel retainer



### ● AK-F1A

with straight flat chisel



### ● AK-F2

with bent wide flat chisel

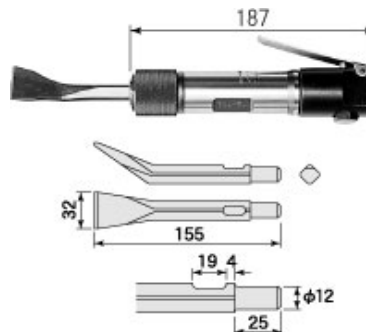

### ● Optional chisels for U-F1A



Long Straight Flat Chisels

LENGTH: 150mm, 180mm, 200mm

### ● Optional chisels for U-F2

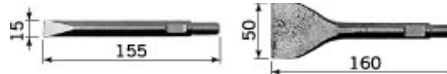

Straight Flat Chisel

Wide Flat Chisel

Model	Piston Dia. (mm)	Piston Stroke (mm)	Blows (bpm)	Air Cons. (L/min)	Air Inlet (inch PT)	Weight (kg)	Overall Length (mm)	Shank Size (mm)	
								Round	Hex.
AK-AA10A	24	51	2800	400	1/2	4.2	295	17.5x60	15x60
AK-AA15A	24	70	2200	500	1/2	4.6	330	17.5x60	15x60
AK-AA20S	28	55	2600	500	1/2	5.7	315	17.5x60	15x60
AK-AA30S	28	79	2200	500	1/2	6.2	345	17.5x60	15x60
AK-F1A	20	12	5000	150	3/8	0.9	175		11x19
AK-F2	22	22	4000	250	3/8	1.2	187		12x25



SAITAMA SEIKI CO., LTD.

2942 Mishiri, Kumagaya, Saitama, 360-0843 Japan  
Tel. +81-48-532-3804 FAX +81-48-533-3883

201304



# CHISELS & Silencer for chipping hammers

## ● Chisels with "Guard Ring"

- SHANK TYPE  
[ROUND]



[HEXAGONAL]

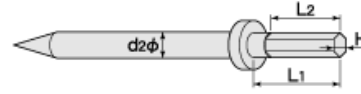

- EDGE TYPE  
[Moil Point]



[Blunt]



[Flat]



[Wide Flat]



Models	Shank Type		Round(mm)		Hex.(mm)			(mm)	Edge Type	Edge Width W(mm)	Length(mm)	
			D	L1	H	L1	L2				d2	standard
AK-NC0S AK-NC0H	ROUND	HEX.	12.7	47	11	47	30	16	Moil Point Blunt	40 (Wide Flat)	200	300,400,500,600 & 800
NC & AA series	ROUND	HEX.	17.5	60	15	60	40	20	Flat Wide Flat	70 (Wide Flat)	300	200,250,400,500,600,800, 1000,1500,2000 & 2500

- Wide flat chisels with chisel retainers

Wide-eged chisels cannot be put in the chipping hammers with chisel retainers.

A set of chisel and retainer spring (pre-assembled) should be chosen for replacement.

A	NC/AA20S,30S
B	AA10A,15A
C	NC0



## ● Chisels without guard ring

SHANK

Round



Hex.

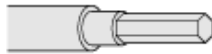

EDGE

Moil Point



Flat



Models	Shank Type		Edge Type	Edge Width	Length(mm)
				W(mm)	
AK-NC0S AK-NC0H	ROUND	HEX.	Moil Point Flat	35 (Standard Flat)	200,300,400,500,600,800,1000,1500 & 1800

## ● Silencer for NC-series



SAITAMA SEIKI CO., LTD.

2942 Mishiri, Kumagaya, Saitama, 360-0843 Japan

Tel. +81-48-532-3804

201304



# SAND RAMMERS

## APPLICATIONS

Sand ramming for casting. Hardening the heat-proof bricks. Undergrounding gas and water pipes. Rolling compression for oil and gas tanks. Dam and public works.

### ● AK-FR00



### ● AK-FR00L



### ● AK-FR0



### ● AK-FR0L



### ● AK-FR1B



### ● AK-FR1



### ● AK-FR2



Model	Piston Dia. (mm)	Piston Stroke (mm)	Blows (bpm)	Air Cons. (L/min)	Air Inlet (inch PT)	Weight (kg)	Length(mm)		Standad Butt	
							Min.	Max.	Inner(mm)	Outer(mm)
AK-FR00	18	50	1800	400	3/8	2	230	430	11.5	40
AK-FR00L	18	50	1800	400	3/8	3	740	940	11.5	40
AK-FR0	22	65	1000	500	3/8	3	277	470	13.5	50
AK-FR0L	22	65	1000	500	3/8	4	796	989	13.5	50
AK-FR1B	25.4	100	800	650	3/8	6	400	619	17.3	65
AK-FR1	25.4	100	800	650	1/2	8	946	619	17.3	65
AK-FR2	32	127	700	850	1/2	9.4	987	1165	19	75

### ● Butts for sand rammers

MODEL	Inner dia.	STANDARD	OPTIONAL	OPTIONAL
		RUBBER	RUBBER	IRON
		Outer dia. (mm)		
AK-FR00	11.5	40	52	40
AK-FR00L				
AK-FR0	13.5	50	60	49
AK-FR0L				
AK-FR1B	17.3	65	-	59
AK-FR1				
AK-FR2	19	75	-	69

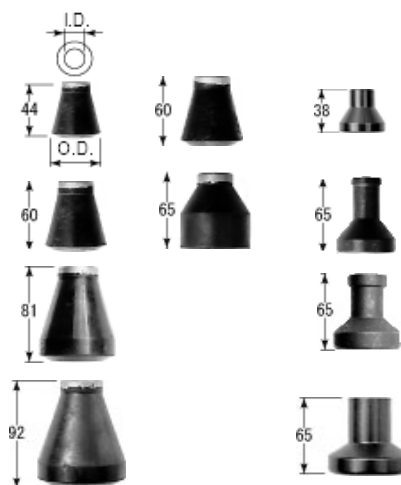

SAITAMA SEIKI CO., LTD.

2942 Mishiri, Kumagaya, Saitama, 360-0843 Japan

Tel. +81-48-532-38(FAX +81-48-533-3883

201304